

Oresus User Manual



Copyright © 2006-2011 HyperSynth

www.HyperSynth.com

rev2.0

Table of Contents

- **About This Manual**
- **Signal Flow**
- **Complex Oscillator I/II**
- **Filter I/II**
- **LFO I/II**
- **S&H**
- **Amp ENV**
- **Mod ENV**
- **Unison**
- **Modulation matrix**
- **Gate/Step LFO**
- **Master**
- **Tips**
- **Support Info**

About This Manual

This manual assumes you have some knowledge about subtractive synthesizers, so it does not go into the depth of certain concepts such as how Filter, LFO or ENV work in detail. There are plenty of resources on the Internet for information about the craft of sound synthesis.

Signal Flow

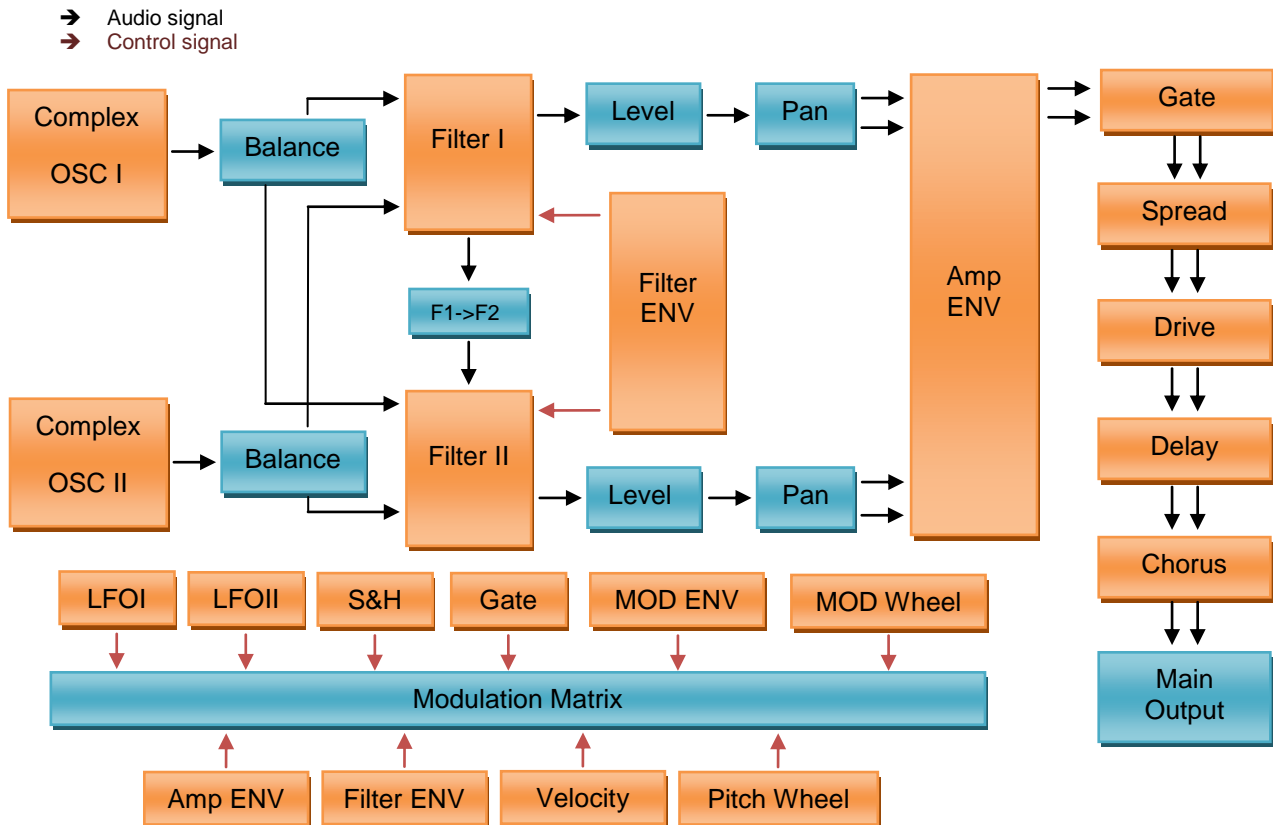

Complex OSC I/II

- **Shape A/B selector:** determines the waveshape of sub oscillator A/B (sin, saw, tri, sqr, noise)
- **Octave selector:** determines the transpose value of sub oscillator A/B in octave (+/-4 oct)
- **Fine knob:** detunes sub oscillator A and B.
- **PW knob:** determines the amount of pulse width (sqr wave must be selected as waveshape).
- **Level A slider:** sets sub oscillator A level. Negative values invert the waveshape.
- **Level B slider:** sets sub oscillator B level. Negative values invert the waveshape.
- **WSM slider:** Mixes waveshape A and B together.
- **WSM A>B/A<B button:** determines modulation source for waveshape modulation. If A>B is selected it means that waveshape modulation runs with sub oscillator A fundamental frequency which results in switching between shape A and B with sub oscillator A freq. If A<B is selected it means that waveshape modulation runs with sub oscillator B fundamental frequency and so on.
- **Phase knob:** sets the start phase for OSC I.
- **Phase sync A-B button:** Forces sub A and B to be phase locked, otherwise they get random phase at each key press.
- **Sync OSC I<-II button:** synchronizes fundamental frequency of oscillator I with frequency of oscillator II, producing "hard sync" effect. In order for synchronization to occur oscillator II must be set to some frequency preferably lower than the frequency of oscillator I.

- **FI->FII knob:** determines how much signal from oscillator is fed through the filter I or filter II. (Oscillator balance)

Filter I/II

- **Freq knob:** sets the freq of filter I/II.
- **Res knob:** sets the resonance amount for filter I/II.
- **Trk knob:** sets the key tracking amount which modulates the filter frequency. For example, it makes filter frequency higher as you play higher notes on the keyboard or lower as you play lower notes.
- **Env knob:** determines the depth of filter envelope.
- **Type selector:** determines filter type:
 - ✓ Bypassed (none)
 - ✓ LP 2 pole (low pass 12db)
 - ✓ HP 2 pole (high pass 12db)
 - ✓ BP 2 pole (band pass 12db)
 - ✓ Notch 2 pole (notch filter 12db)
 - ✓ LP 4 pole (low pass 24db)
 - ✓ HP 4 pole (high pass 24db)
 - ✓ BP 4 pole (band pass 24db)
 - ✓ Notch 4 pole (notch filter 24db)
 - ✓ LP TB303 (low pass filter which emulates the sound of Roland TB303)
 - ✓ LP Moog (low pass filter which emulates the sound of famous Moog ladder filter)
 - ✓ Hyper LP8 (low pass 48db filter which has a vocal formant like character)
 - ✓ Hyper HP6 (high pass 36db filter which has a vocal formant like character)
 - ✓ (Note: LP TB303 is only selectable via filter I and LP Moog via filter II)
- **Filter env-A slider:** sets the amount of attack time.
- **Filter env-D slider:** sets the amount of decay time.
- **Filter env-S slider:** sets the amount of sustain level.
- **Filter env-R slider:** sets the amount of release time.
- **Filter env-Acrv:** sets the amount of slope for Attack curve which is adjustable from – exponential function to linear then to + exp.
- **Filter env-Dcrv:** sets the amount of slope for Decay curve which is adjustable from – exponential function to linear then to + exp.
- **FI out slider:** sets the amount of filter I output level.
- **FI->FII slider:** determines how much signal from filter I output is fed through filter II input.
- **FII out slider:** sets the amount of filter II output level.
- **FI pan slider:** sets the amount of filter I panning.
- **FII pan slider:** sets the amount of filter II panning.
- **FII reverse polarity:** reverses the polarity of filter II signal which is useful to generate uncommon filter types.

LFO I/II

- **Freq knob:** sets LFO freq (0.001-20.000 Hz).
- **Sync button:** synchronizes LFO freq to host tempo.
- **Retrig button:** forces LFO waveshape to start at the beginning.

S&H

- **Freq knob:** sets S&H freq (0.001-39.999 Hz).
- **Sync button:** synchronizes S&H freq to host tempo.
- **Input selector:** determines the input signal for S&H module.
- **Smooth knob:** smoothens the sampled waveform.

Amp ENV

- **A slider:** sets the amount of attack time.
- **D slider:** sets the amount decay time.
- **S slider:** sets the amount of sustain level.
- **R slider:** sets the amount of release time.
- **Acrv:** sets the amount of slope for Attack curve which is adjustable from – exponential function to linear then to + exp.
- **Dcrv:** sets the amount of slope for Decay curve which is adjustable from – exponential function to linear then to + exp.

Mod ENV

- **A slider:** sets the amount of attack time.
- **D slider:** sets the amount decay time.
- **S slider:** sets the amount of sustain level.
- **R slider:** sets the amount of release time.
- **Acrv:** sets the amount of slope for Attack curve which is adjustable from – exponential function to linear then to + exp.
- **Dcrv:** sets the amount of slope for Decay curve which is adjustable from – exponential function to linear then to + exp.

Unison

- **Detune knob:** detunes unison voices.
- **Widen knob:** sets the amount of stereo separation for unison voices in stereo mode.
- **Voices selector:** sets the number of unison voices. It must be set to “**unison off**” for disabling unison effect.
- **Mode selector:** sets unison mode: Mono, Stereo. Stereo mode causes “Filter I” and “Filter II” to be linked together as this type of unison needs two filters per voice, so you cannot change Filter II independently. It also sets proper values for **FI Pan**, **FII Pan**, **OSCI Balance** and **OSCII Balance** automatically.

Modulation Matrix

- **Source selector:** determines the modulation source (None, LFOI Sin, LFOI Saw, LFOI Tri, LFOI Sqr, LFOI Noise, LFOII Sin, LFOII Saw, LFOII Tri, LFOII Sqr, LFOII Noise, S/H, MOD ENV, Filter ENV, Amp ENV, Mod wheel, Pitch Wheel, Note Velocity, Gate Level).
- **Depth knob:** determines the modulation depth.
- **Destination selector:** determines the modulation destination (None, FilterI Freq, FilterI Res, FilterI Pan, FilterI Level, FilterII Freq, FilterII Res, FilterII Pan, FilterII Level, OSCI PitchWide, OSCI PitchNarrow, OSCI PW, OSCI WSM, OSCI Level, OSCI Phase, OSCII PitchWide, OSCII PitchNarrow, OSCII PW, OSCII WSM, OSCII Level, OSCII Phase, LFOI Freq, LFOI Depth, LFOII Freq).

Gate/Step LFO

- **Gate On/Off button:** enables/disables the gate function.
- **Gate Mix knob:** sets the amount of (unprocessed) signal to be mixed with the gate output signal.
- **Gate Contour knob:** smoothens the audio level between the gate steps.
- **Step LFO Smooth knob:** smoothens the step lfo output signal.
- **Step LFO Wave Selector:** lets you select a pre-defined waveform for step lfo.
- **Steps 1-16:** sets the note on/off for gate (red color steps show step 1, 4, 8 and 12). Orange bars determine step lfo values.
- **Rate selector:** sets the gate/step lfo speed which is synced to host tempo.

Master

- **Voice selector:** limits the polyphony of synthesizer, useful when the patch is CPU hungry.
- **Porta knob:** if it is set to a non-zero value will adjust the portamento time and force the synthesizer to function monophonically.
- **Spread knob:** sets the amount of stereo spread effect.
- **Drive On/Off button:** enables/disables the analog overdrive effect.
- **Drive knob:** sets the amount of overdrive.
- **Delay-Time knob:** sets the amount of delay time in millisecond.
- **Delay-Sync button:** synchronizes delay time to host tempo.
- **Delay-Type selector:** determines the delay algorithm (ping-pong delay, cross delay).
- **Delay-Feed knob:** sets the amount of feedback for delay.
- **Delay-Dry-Wet knob:** sets the amount of "dry" (unprocessed) signal to be mixed with the "wet" (processed by the effect) signal.
- **Delay-On/Off button:** enables/disables the delay effect.
- **Chorus-Rate knob:** sets the amount of chorus rate.
- **Chorus-Depth knob:** sets the amount of chorus depth.
- **Chorus-Predelay knob:** sets the amount of chorus predelay time.
- **Chorus-Mix knob:** sets the amount of unprocessed signal to be mixed with chorus effect signal.
- **Chorus-On/Off button:** enables/disables the chorus effect.
- **Volume knob:** sets the main output level.

Tips

- If you press **shift** key while tweaking a knob, its value will change more precisely. **Ctrl + left click** sets the knob position to the default value. In Step LFO **Double right** click will reset all steps to zero.
- Clicking over Oresus logo shows the about page.

Support info: If you encounter any problems, or you have suggestions for future revisions, don't hesitate to contact our technical support at: Support@hypersynth.com

